

(No Model.)

G. A. NEITZEL.

ATTACHMENT FOR MOLDING OR TURNING MACHINES.

No. 504,111.

Patented Aug. 29, 1893.

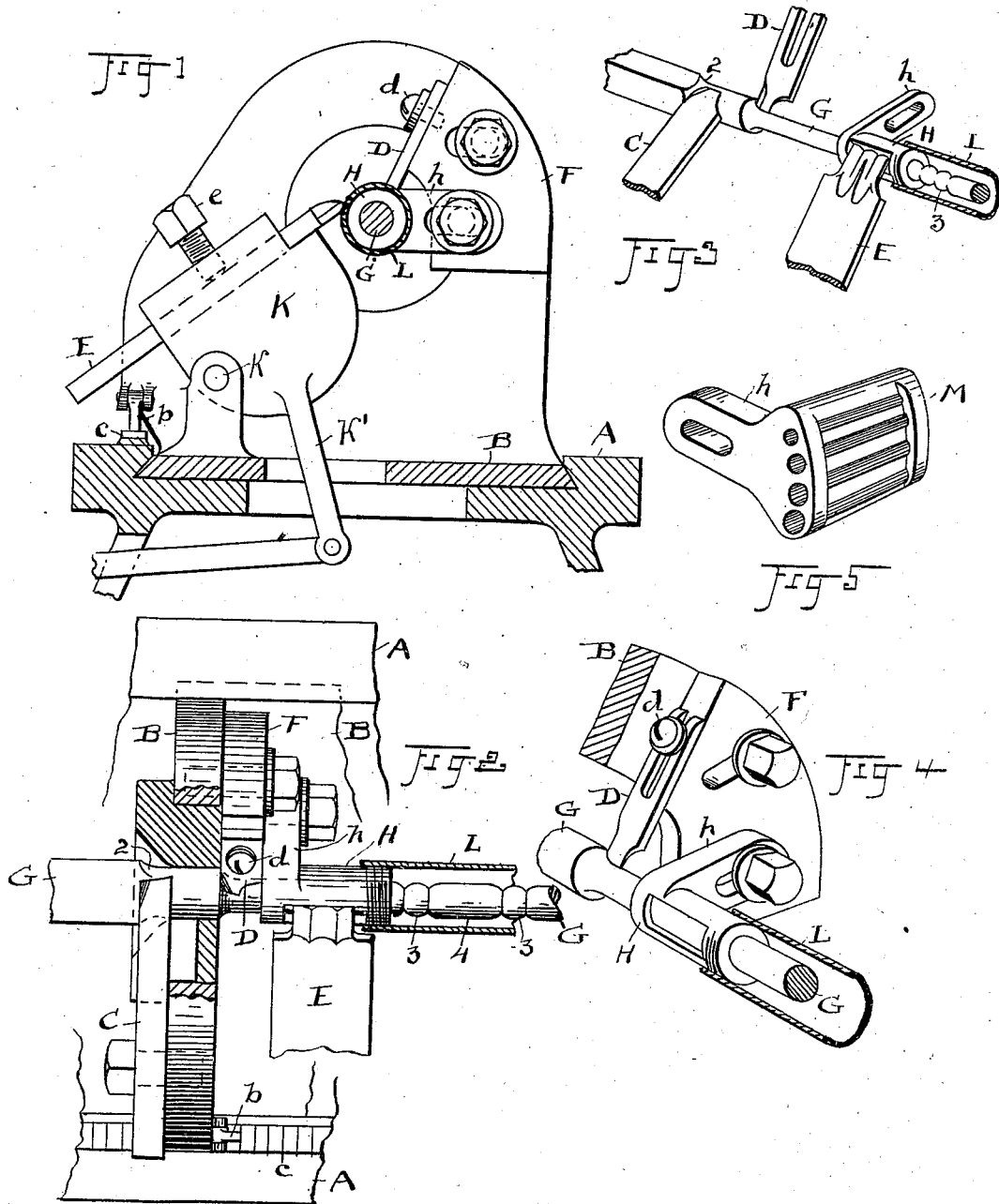

ATTEST

W. B. Moser,
B. S. Schaeffer,

INVENTOR
By H. J. Fisher, GEORGE A. NEITZEL.

ATTORNEY.

UNITED STATES PATENT OFFICE.

GEORGE A. NEITZEL, OF BEDFORD, OHIO.

ATTACHMENT FOR MOLDING OR TURNING MACHINES.

SPECIFICATION forming part of Letters Patent No. 504,111, dated August 29, 1893.

Application filed January 28, 1893. Serial No. 460,007. (No model.)

To all whom it may concern:

Be it known that I, GEORGE A. NEITZEL, a citizen of the United States, residing at Bedford, in the county of Cuyahoga and State of Ohio, have invented certain new and useful Improvements in Attachments for Molding or Turning Machines; and I do hereby declare that the following is a full, clear, and exact description of the invention, which will enable others skilled in the art to which it appertains to make and use the same.

My invention relates to attachments for wood turning machines, and the object of the invention is to provide a machine whereby wood may be turned to a greatly reduced form. Heretofore with the different machines or means of turning known to me, it has been impracticable to turn the same to as fine a point as I am now able to do, for the reason that there were no appropriate means of holding the same and of doing the work in this finer condition.

My invention, therefore, consists in the construction of a wood turning device adapted to be attached and operated substantially as hereinafter shown and described and particularly pointed out in the claims.

In the accompanying drawings, Figure 1 is a cross section of a machine or lathe upon which my attachment is supported, and showing my attachment in side view looking in from the right of Fig. 2. Fig. 2 is a plan view of the attachment as shown in Fig. 1, but partly broken away on top. Fig. 3 is a perspective view showing the position and relation of the three several knives to one another and to the work, and showing a piece of work as it appears when undergoing operation, and a finishing holder with the finishing knife in position in respect to said holder, as it appears in use. Fig. 4 is a perspective view of a portion of the machine showing one of the holders with a piece of the work passing through it, and one of the knives engaged on said work. Fig. 5 is a perspective view of a modified form of holder or holder head, in which there are different sizes or channels or grooves for the work to pass through, according to the size of work made.

A represents a suitable frame, as the frame of an ordinary lathe, and B is a supplementary

frame or head having a dove-tailed or beveled base adapted to be held and to slide back and forth in the base A, as the work progresses. This frame or head B carries my improved mechanism, and this mechanism is comprised in three several knives C, D and E. The knife C is what may be termed the roughing knife or blade, or cutter, which takes the material in its rough form and reduces it to the cylindrical form seen at 2 Fig. 3. This knife is supported upon the frame B at the side thereof, as seen in Fig. 2. The second knife or blade, or cutter, by which the size of the material is made, is secured adjustably by a set screw *d*, passing through its slotted end and fixed to the slotted adjustable block or head F, which is secured upon the frame B by bolts passing through slots in said block. This sizing knife can be adjusted to a finer or heavier cut, as may be desired. That is, it may be used to make a smaller or larger size of the material G, upon which it is shown at work in Figs. 3 and 4. After the material has passed this blade or knife, it becomes so reduced that it cannot well be cut to smaller dimensions at any point without some special means of holding it, and for this purpose I have provided a holder H having a slotted arm *h* through which it is bolted adjustably to the head F. A cylindrical channel or groove extends through this head H, through which the material G passes after it leaves the sizing blade, and I keep different sizes of heads, according as I want to make the material larger or smaller. In some instances it is larger relatively than shown in the drawings, and in others it is smaller, and I have heads to suit the different sizes. The material is constantly rotated by any suitable means and the knives are stationary, and the head or frame B carrying the knives is carried up to the material as the said material is reduced to the form and shape desired. Now, having a reduced cylindrical stem, as seen in Figs. 3 and 4, I subject the same to the action of the knife or blade E, which is constructed to give the material whatever shape I may desire for it. That is to say, I may fashion a series of small ball shaped sections, 3, as seen in Fig. 2, with intervening tubular sections 4, or I may have a close succession of the balls

3 cut to a greater or less depth between them, as may be desired. Or, indeed, I may cut the said material into still different forms by means of the knife or blade E, and am enabled to do exceedingly fine work by reason of the head H holding the material in such way that this work can be done. As here shown, the said head has an opening on the working side thereof through which the blade E is introduced. This opening may extend the entire length of the head, or only along at the middle part. The said blade E is supported upon a suitable block K, pivoted at *k*, and having an arm *k'* with a link connection going to a treadle, through which the block or head K is thrown to or away from the stock or material G. The said blade or cutter E likewise is adjustable back and forth by means of the set screw *e*, so as to adapt it to the work. The frame B has a pawl *b* at its front adapted to engage in the rack bar *c*, so as to hold it in position as it is fed along by hand, the operator doing the feeding or moving of the machine when necessary and seeing that the knives are kept in their proper relations to the work, and that they work as they should.

In Fig. 5, I show a holder M which is designed to take the place of the holder H, and which is provided with a series of graduated grooves or channels adapted to be adjusted into position according to the size of the material used for the time being, and to hold the same just as the single holder does.

In order to support the material or stock, which is so finely reduced by the cutting knives as to endanger its integrity in any considerable length, I have provided a tube or support L for the said stock, into which the stock passes after it leaves the finishing knife. This tube is designed to be large enough to accommodate the stock of different

sizes as it comes from the machine, and it is shown here as temporarily or movably attached to the head F. It might be otherwise attached, but this serves a very good purpose, and the head is threaded in order to effect this attachment.

Having thus described my invention, what I claim is—

1. The construction herein described comprising the sliding supporting frame B, the adjustable head F on said frame, and the adjustable material holder detachably secured to the head F, in combination with the pivotally supported bearing block K, and the finishing knife E adjustable in said block, substantially as set forth.

2. The attachment herein described having the adjustable head and the sizing knife D adjustable on the top inclined plane of the head F, in combination with the material holder adjustably secured to the side of the said head through the arm —*h*—, substantially as set forth.

3. In the attachment described, the frame B, the head F thereon, and the material holder adjustable on said head and provided with a tubular extension through which the material passes, in combination with a receiving tube connected to said tubular extension to prevent the finished material from breaking, substantially as set forth.

4. In combination with the attachment described, the adjustable holder for the material having two or more parallel cylindrical channels of varying diameters, each channel open part way in front for the introduction of a cutting blade and one channel above the other, substantially as set forth.

GEORGE A. NEITZEL.

Witnesses:

H. T. FISHER,
GEORGIA SCHAEFFER.